

33620 DK-M

Electric Ceramic Hob Operating Instructions

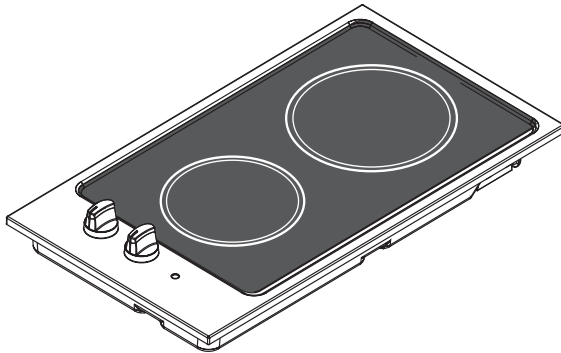

PERFEKT IN FORM UND FUNKTION

Congratulations from AEG

Dear Customer,

Congratulations with your new Hob.

It is important that you become familiar with the functions and features of the Hob. You should therefore read these operating instructions as they will help you get the most out of your new Hob.

Pay extra attention to sections marked . These are warning texts to help you avoid accidents.

Keep the operating instructions. They will come in handy if there is something you are not sure about, and should accompany the Hob if it is transferred to a new owner.

The structure of the operating instructions enables you to use them as a reference manual. The first part of the operating instructions contains a general description of your new product. Then follows a short introduction of the things to do before you use the Hob for the first time. The section “How to use” describes how the Hob is used in everyday life. Use this section until you are familiar with your new Hob. The section “Cleaning and Maintenance” provides information on both daily and more thorough cleaning of the individual components of the Hob. Should problems arise when you use the Hob, you can look in the section “Before calling service”, where there are instructions on how to remedy some practical and technical problems yourself.

Enjoy!

Regards,

AEG

Table of contents

Contents	Page no
----------	---------

For the user

Congratulations from AEG	3
Safety information	5
Description of the product	6
How to use	7
Pilotlight	8
Residual-Heat indicator	8
Advice and hints for using the cooking zones	9
Cleaning and maintenance of	11
Stainless steel surfaces	11
The ceramic glass hob	11
Tips on the use of the ceramic hob unit	12

For the installer

Installation	14
Electrical connection	15
Building in dimensions	17
Technical Data	19

How to read the operating instructions:

1... 2...Step by step

 Hint and tips

 Safety information

 Environmental information



Safety information

These warnings are provided in the interests of your safety. Ensure you fully understand them before installing or using the appliance. Your safety is of paramount importance. If you are unsure about the meaning of these warnings contact the Customer Care Department for assistance.

Installing

Do not install the hob if the ceramic glass is damaged or cracked.

This hob must be installed according to the instructions supplied. Any installation work must be undertaken by a qualified competent person.

Do not alter the specifications or attempt to modify the appliance in any way.

During Use

The hob is intended for domestic cooking only. It is not designed for commercial/industrial purposes.

Ensure that all the control knobs are in the OFF position when not in use.

Do not use the hob if it is damaged in any way, contact your local AEG Service Centre.

Never use plastic or aluminium dishes on the hob.

Never leave the hob unattended while deep fat frying, or heating fats and oils.

The appliance is not intended for use by young children or infirm persons without supervision.

Child Safety

Young children should be supervised to ensure that they do not play with the appliance

The hob gets hot when it is in use. Children should be kept away until the hob has cooled.

Maintenance and Cleaning

Only clean this hob in accordance with the instructions given in this book.

Service

Repairs carried out by inexperienced persons may cause injury or serious malfunction of the appliance. Repairs must only be carried out by a qualified/competent person. Contact your local AEG Service Centre.

Disposal

Make the hob unusable by cutting off the cable.

Dispose of any packaging material and old appliances at an authorised disposal site.

Description of the product

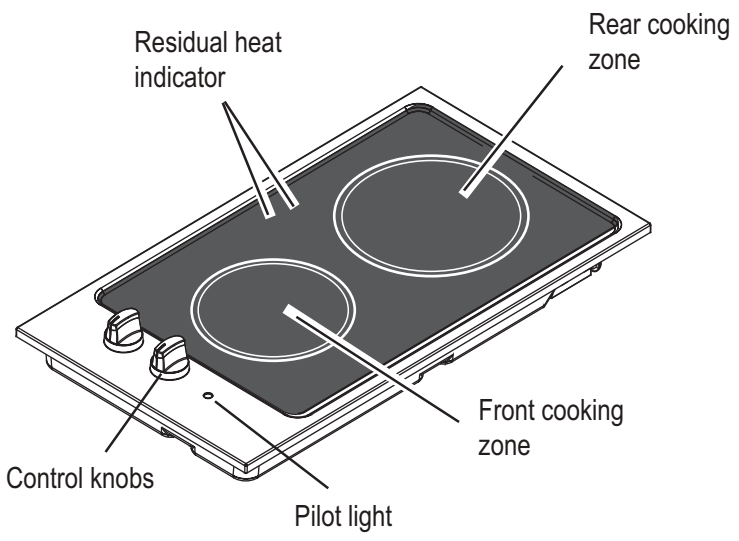

How to use

Control knob (to the left)

- Control knob for regulating the plate at the rear
- Control knob for regulating the plate at the front.

Regulating

The regulating of heat is graduation-free for both plates on a scale from 1 to 3.

- “1” Represents lowest heat
- “3” Represents maximum heat.
- “0” Represents “OFF”.

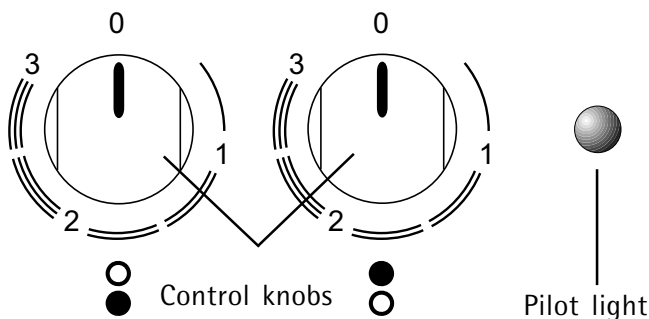

- i** Do not use the ceramic hob if the glass is damaged. If a fault or crack appears during cooking disconnect the hob immediately and contact AEG Service.

Pilot light

Pilot light is activated when either of the zones are turned on, and will remain on until the cooking zones are switched off.

Residual-Heat indicator

Each plate has a residual heat indicator which remains on as long as the temperature of the cooking zone exceeds 80°C, even if the cooking zone is switched off.

Settings for ordinary cooking zones

Step	Function
0	The cooking zone is switched off
·	Keeping warm
1	Gentle simmering
·	Simmering
2	Frying / browning
· - 3	Bringing to the boil / quick frying / deep-frying

This table should be used as a guide only. The settings depend on the saucepan you use, quantity and contents. After a while you will learn to choose the correct settings. See also the section “Advice and hints for using the cooking zones”.

Advice and hints for using the cooking zones

 If you use the advice below you will save energy and make your cleaning tasks easier.

Adjust the cooking zones correctly. Select the highest setting for the cooking zones until the food is brought to the boil. Then reduce the setting as far as possible, without the food going off the boil.

 Use level saucepans. An uneven saucepan may increase the electricity consumption by up to 50 per cent. Check whether your saucepans have level bases by placing the item in question upside down on a work top and positioning a ruler on the base. A curved base, both inwards and outwards, will prolong the cooking time and increase the energy consumption

 The saucepan should match the cooking zone – or be slightly larger. Remember that a large saucepan can also hold small quantities. If the diameter of the base is too small, the energy consumption will increase, and any food boiling

over will burn onto the hot cooking zone.



Saucepans with very shiny/bright bases will prolong the cooking time slightly compared with cooking utensils with matt/dark bases.



Use a tightly fitting lid on the saucepan. Without a lid you use more than three times as much electricity.

Check whether your cooking utensils has level bases by placing the item in question upside down on a work top and positioning a ruler on the base. A curved base, both inwards and outwards, will prolong the cooking time and increase the energy consumption. If the diameter of the base is too small, the energy consumption will increase, and any food boiling over will burn onto the hot cooking zone.

Cooking utensils with very shiny/bright bases will prolong the cooking time slightly compared with cooking utensils with matt/dark bases.

Cleaning and maintenance of



For reasons of hygiene and safety, the cooking zones must be kept clean. Grease stains and spilled food generate smoke when heated, and can even cause fire.

Never use metal wool, metal sponges or other abrasive cleaning agents.

The ceramic glass hob

Immediately scrape off stains caused by food which has boiled over using the scraper supplied with the hob, spilled sugar, dishes containing sugar (jam, juice, etc.), melted plastic and aluminium foil while the ceramic hob is still hot. If the ceramic hob is allowed to cool it may become damaged. A dirty ceramic hob decreases the heat transfer between cooking zones and cookware.

After use the cooking zones should be wiped with a damp cloth with washing up liquid. For severe soiling you can follow these steps:

1. Remove stains etc., with the ceramic hob scraper.
2. Make sure that the ceramic hob has cooled down. Use a ceramic cleaning agent, such as vitrocLEN.

3. Wipe the ceramic hob clean with a damp cloth or kitchen roll. Tough stains can be removed by rubbing the stain hard with kitchen roll.
4. Wipe off remaining cleaning agent with a damp cloth.
5. Wipe with a dry cloth, if required.

Make sure that the ceramic hob is dry when you heat it up again. Ceramic hobs can develop rainbow-like stripes if heated while damp.

Stainless steel surfaces

Clean the appliance after use with a soft cloth well wrung out in warm water, use a small amount of liquid detergent for stubborn soiling. Stainless steel parts may become straw coloured with use, use a proprietary stainless steel cleaner to remove this straw discolouration.

Tips on the use of the ceramic hob unit

Do not slide saucepans across the surface of the hob - always lift the pan when placing it on, or removing it from the ceramic surface.

Wipe the bottom surface of the pots and pans with a clean dry cloth before placing them on the ceramic surface. This helps to reduce cleaning and prevents scratching the hob glass.

Wipe off spills whilst the hob is warm.

Select the highest setting for the cooking zones until the food is brought to the boil, then reduce the setting.

Use saucepans with an even base. An uneven based saucepan may increase the electricity consumption by up to 50%.

The saucepan should match the cooking zone or be slightly larger.

Use a tightly fitting lid on the saucepan to reduce electricity consumption.

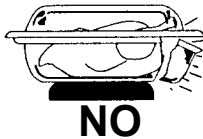

The decorative pattern on the ceramic surface can become scratched and marred with use, depending upon maintenance, but does not adversely affect performance.

Such blemishes are not covered by the warranty and do not affect the operation of the hob.

Spills and melts must be removed immediately, while the surface is still warm, using the scraper supplied with the unit. Especially damaging are melted plastic, aluminum, or any foodstuff containing sugar, including natural sugar, as these can create permanent “pockmarks” and craters on the ceramic surface. After scraping polish thoroughly with the cleaning agent supplied with the unit.

Utensils which have been in contact with the above-mentioned melted materials must be cleaned thoroughly before used again on the ceramic-top hob unit.

Defects in the ceramic surface which can be related to the above are not covered by the warranty.

Warning:

Aluminum foil and plastic utensils are not to be placed on hot surfaces. The surface may not be used for storage.

Do not stare at the heating units when in operation.

Installation

Warnings about electrical connection

- Any electrical work required to install this hob should be carried out by a qualified electrician or competent person, in accordance with the current regulations.
- Before the appliance is connected:
 - 1) check that the main fuse and the domestic installation can support the load;
 - 2) check that the power supply is properly earthed in compliance with the current rules;
 - 3) check the socket or the double pole switch used for the electrical connection can be easily reached with the appliance built in the furniture unit.
- This hob is designed to be connected to a 230V single-phase 50 Hz AC 220 V, 60 Hz electrical supply.
- This hob has been registered as a “Class Y” appliance according to Fire Risk Protection Regulations. It can be built-in in furniture units placed near higher walls or units, provided that one of the sides is adjacent to an unit with the same height.
- If connecting the hob directly to the power mains, a double pole switch should be fitted, with a minimum gap of 3 mm. between the switch contacts and of a type suitable for the required load in compliance with the current electric regulations. The switch should be sited within 2m of the hob and be easily accessible upon completion of the installation.
- Proper arrangements must be taken in designing the furniture unit, in order to avoid any contact with the bottom of the hob which can be heated when it is operated. Before any intervention, ensure the hob is disconnected from the electricity supply.
- Once connection has been carried out, test heating elements for about 3 minutes.
- The minimum distance combustible material can be fitted above the hob in line with the edges of the hob is 420 mm.
- It is not allowed to install an oven under the hob.

Electrical connection

This hob is provided with a connection cable type H05 VV₂-F T90, section 3 x 1,5 mm². A suitable plug must be fitted to the cable and then connected to a suitable plug, according with specification given on the rating plate.

If connecting the hob directly to the power mains, a double pole switch should be fitted, with a minimum gap of 3 mm. between the switch contacts and of a type suitable for the required load in compliance with the current electric regulations.

The switch must not break the yellow and green earth cable at any point.

Ensure that the hob supply cord does not come into contact with surfaces whose temperature exceed 90 °C over room temperature..

Replacement of connection cable

The connection of the voltage cable to the appliance's terminal block is of type "Y". This means that its replacement requires the specific equipment of a technician.

In this case, only cable type H05V2V2-F T90 must be used. The cable section must be suitable to the voltage and the working temperature.

The yellow/green earth wire must be approximately 2 cm. longer than the phase wires .

Warnings about building in the hob

- Ensure the eventual plastic covering of the furniture unit has been fixed with a heatproof adhesive (100°C heatproof).
- Fitting of solid wood panel borders on the working top or behind the hob is allowed provided that minimum distances are observed.
- A insulation panel which can only be removed with tools must be fitted under the hob at a minimum distance of 50 mm.
- If the hob must be installed beside a cupboard, ensure a minimum distance of 40 mm. is observed and the side of the cupboard is covered with heatproof material.
- Before making the cut out in the worktop ensure that the edges of the hob that are to be near the rear wall have a minimum distance of 55 mm.
- A minimum distance of 100 mm. must be observed between the hob and an eventual side wall exceeding the working top height.
- Hanging furniture units or cooker hoods must be fitted at a minimum height of 650 mm. from the hob.
- Combustible or not heatproof materials must be kept away from the appliance.

Building in Dimensions

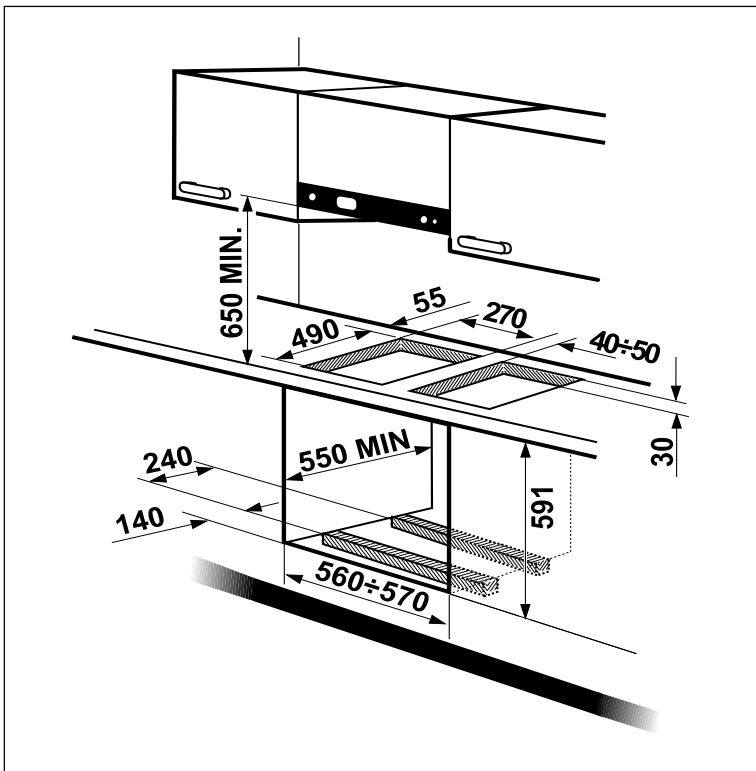

Cut Out Size

The dimensions of the cut-out are given in the diagram.

If 30 cm. hobs with different functions must be built in one beside the other (e.g. 2 Plate Hob + 2 burners Hob), the minimum distance shown in the diagram must be observed.

Securing the hob into the cut out

Before fitting the hob into the cut out, the sealing gasket supplied with the hob must be fitted to the edge of the cut out. It is essential that no gaps are left in this seal in order to prevent spillage near the hob seeping into the cabinet below.

- 1) Place the sealing gasket (A) all around the edge of the cut out.

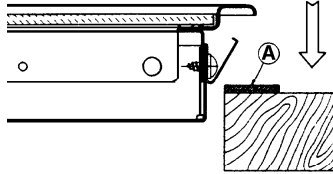

- 2) Fit the hob in the cut out and push it down until it comes in contact with the kitchen top surface. Then remove the excess sealing.

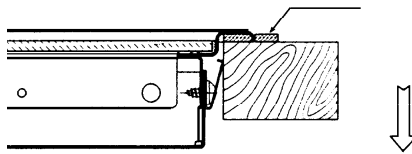

- 3) To remove the hob from the cut-out, lift the edge of the hob by means of the edge of a screw-driver.

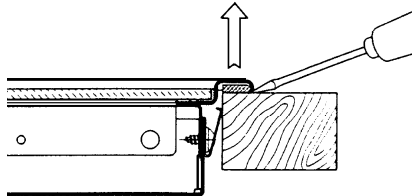

Proper arrangements must be taken in designing the furniture unit, in order to avoid any contact with the bottom of the hob which can be heated when it is operated.

The recommended solution is shown in diagram.

The panel fitted under the hob should be easily removable to allow easy access if technical assistance is needed.

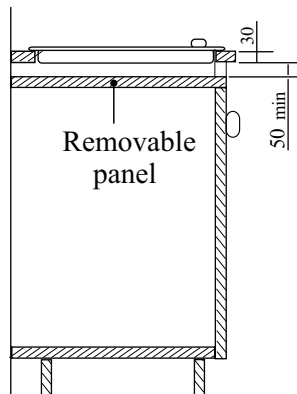

Technical data

Dimensions in mm: Hob H x W x D Cut Out W x D	8 x 290 x 510 270 x 490
Heating Elements Ratings in Watt: Front Hotplate Ø 145 mm. Rear Hotplate Ø 180 mm.	1200 2900
Total rating in Watt	3000
Electrical supply	230 V, 50 Hz

CE This appliance is manufactured according to the following EEC directives:

73/23 EEC - 90/683 EEC - 93/68 EEC - 89/336 EEC current edition.

Servicing

If you are not able to find any hint for a fault in this Instruction Book, you should contact our After-sales Service.

When calling for an engineer, please remember you will be requested to specify the following data:

E-Nr. _____

F-Nr. _____

which are quoted on the label attached on the back cover of this Instruction Book.

These data enable the After-sales Service to make a focused spare part specification, so that your hob can be repaired at the first engineer visit.

This will save you the additional costs of any possible repeated visits by the After-sales engineer.

AEG Hausgeräte GmbH

•

- © Copyright by AEG
Sie können Ersatzteile, Zubehör und Pflegemittel
on-line bestellen unter ***<http://www.aeg-electrolux.com>***